



2900-01 NETWORK GATEWAY PRODUCT GUIDE

The information in this document has been carefully checked and is believed to be entirely reliable. However, no responsibility is assumed for inaccuracies. Furthermore, Cyclone Microsystems, Inc. reserves the right to make changes to any products herein to improve reliability, function, or design. Cyclone Microsystems, Inc. neither assumes any liability arising out of the application or use of any product or circuit described herein, nor does it convey any license under its right or the rights of others.

Revision 1.5, September 2014

Cyclone P/N 800-2900-01

Copyright 2014 by Cyclone Microsystems, Inc.

CHAPTER 1 PRODUCT OVERVIEW

1.1 INTRODUCTION 1-1

1.2 SPECIFICATIONS..... 1-2

1.3 REGULATORY COMPLIANCE 1-3

 1.3.1 Safety 1-3

 1.3.2 RFI/EMC 1-4

 1.3.3 Immunity 1-5

 1.3.4 Telecommunications (Pending) 1-5

 1.3.5 Other..... 1-5

 1.3.6 Markings 1-5

CHAPTER 2 FEATURES

2.1 PHYSICAL CONFIGURATION..... 2-1

 2.1.1 2900 Power Supply Switch 2-2

2.2 CONNECTORS 2-2

 2.2.1 Power Connector 2-2

 2.2.1.1 DC Power Connectors (600-2900-xx-D0) 2-3

 2.2.1.2 DC Power Supply Cable 2-3

 2.2.1.3 AC Power Connectors (600-2900-xx-A0)..... 2-3

 2.2.1.4 AC Power Supply Cable 2-4

 2.2.2 Earthing Ground Stud..... 2-4

 2.2.3 Console Connector..... 2-5

 2.2.4 Ethernet Port Connectors 2-6

 2.2.4.1 Intra-Building Interfaces 2-6

 2.2.5 Ethernet Port LEDs..... 2-7

 2.2.6 T1/E1 Connectors..... 2-7

 2.2.6.1 Intra-Building Interfaces 2-7

 2.2.7 T1/E1 Port LEDs..... 2-8

 2.2.8 BITS Clock Connectors 2-8

 2.2.9 BITS Clock LED..... 2-9

 2.2.10 Processor ACT LED 2-9

 2.2.11 Fan Status LED 2-9

 2.2.12 Power Supply Status LEDs 2-9

CHAPTER 3 INSTALLATION GUIDE

3.1 CONSIDERATIONS 3-1

 3.1.1 Equipment Rack Precautions 3-1

 3.1.1.1 Anchor The Equipment Rack 3-1

 3.1.2 Grounding the Equipment Rack 3-1

 3.1.3 Temperature 3-1

 3.1.4 Ventilation..... 3-1

 3.1.5 System References 3-1

 3.1.6 Prerequisite Tools and Supplies..... 3-2

3.2 INSTALLATION INSTRUCTIONS 3-2

 3.2.1 Install Rack Mounted Rails 3-2

 3.2.2 Install the Gateway into a Rack 3-2

 3.2.3 Connect Gateway to Earthing Ground..... 3-2

 3.2.4 Connecting DC Power 3-2

 3.2.5 Connecting AC Power 3-3

3.3	INSTALLATION GUIDELINES	3-3
CHAPTER 4 MAINTENANCE		
4.1	PERIODIC MAINTENANCE	4-1
CHAPTER 5 FIELD REPLACEABLE COMPONENTS		
5.1	SERVICEABLE COMPONENTS	5-1
5.2	MOTHERBOARD REMOVAL AND INSTALLATION	5-1
5.3	FAN TRAY REMOVAL AND INSTALLATION	5-2
5.4	POWER SUPPLY REMOVAL AND INSTALLATION	5-3
5.4.1	Power Supply Removal	5-4
5.4.2	Power Supply Installation	5-4
CHAPTER 6 RELIABILITY CALCULATIONS		
6.1	METHODOLOGY	6-1
6.2	ASSUMPTIONS	6-1
6.3	FAILURE RATE AND MTBF	6-1
CHAPTER 7 WARRANTY AND SERVICE		
7.1	OVERVIEW	7-1
7.2	HARDWARE	7-1
7.3	SOFTWARE AND FIRMWARE	7-1
7.4	EFFECTIVE PERIOD OF WARRANTY	7-1
7.5	REPAIRED OR REPLACEMENT PRODUCT (OUT-OF-WARRANTY)	7-1
7.6	SERVICE POLICY	7-2
APPENDIX A SAFETY		
A.1	INTENDED USES	A-1
A.2	EQUIPMENT RACK	A-1
A.3	POWER	A-1
A.4	IF AC POWER SUPPLIES ARE INSTALLED	A-2
A.5	IF DC POWER SUPPLIES ARE INSTALLED	A-2
A.6	TEMPERATURE	A-3
A.7	VENTILATION	A-3

LIST OF FIGURES

Figure 1-1.	2900-01 Block Diagram	1-2
Figure 1-2.	2900 Part Numbering	1-2
Figure 2-1	600-2900 Rear Panel	2-1
Figure 2-2	600-2900 Front Panel with and without Front Bezel.....	2-2
Figure 2-3	DC Power Connector.....	2-3
Figure 2-4	AC Power Connector.....	2-4
Figure 2-5	Earthing Ground Stud Location	2-5
Figure 2-6.	Ethernet Port LEDs.....	2-7
Figure 2-7.	T1/E1 Port LEDs.....	2-8
Figure 2-8.	BITS Clock Port LED	2-9
Figure 4-1	Air Filter Replacement	4-1
Figure 4-2	Pinching Filter Material	4-2
Figure 5-1.	Air Filter Replacement	5-3
Figure 5-2	600-2900 Front Panel.....	5-4
Figure 6-1	Front End Processor Reliability logic Block Diagram	6-2

LIST OF TABLES

Table 1-1.	600-2900 Specifications	1-3
Table 2-1.	600-2900 Rear Panel Description	2-1
Table 2-2	Ring Lugs for #10 Studs	2-4
Table 2-3.	Console Port Connector	2-6
Table 2-4	Ethernet Port Connector.....	2-6
Table 2-5	T1/E1 Port Connector	2-7
Table 2-6.	BITS Clock Connector	2-8
Table 2-7.	ACT LED	2-9
Table 4-1.	Air Filter Replacement	4-1
Table 5-1.	CLEI Number and Barcode	5-1
Table 5-2	Motherboard Removal	5-2
Table 5-3	Motherboard Installation	5-2
Table 5-4	Fan Tray Removal and Installation.....	5-3

1.1 INTRODUCTION

The 2900-01 Network Gateway is designed for demanding call processing/AIN applications and is typically installed between a telecommunications switch and application gateways. AIN applications facilitate calling services like local number portability, call following, and other advanced telephony services. The gateway uses two processors; a dual core PowerPC processor as a main processor and a Power QUICC (Power PC based communications processor) as a link processor. The two processors are connected by a 20 Gb/s interprocessor bus.

The link processor section of the board features eight T1/E1 ports that may be configured as either ATM or TDM, and two 10/100/1000 BaseT Ethernet ports. The main processor also has two 10/100/1000 BaseT Ethernet ports leading to total of four Ethernet ports.

As the 2900-01 is architected for high reliability systems and typically installed in redundant configurations, there are numerous features to improve system up-time like two redundant hot swappable power supplies, a fault tolerant and field replaceable fan tray, and comprehensive system monitoring.

The 2900-01 is available in either dual AC or dual DC power supply configurations and is supported by VxWorks and Linux BSPs.

Figure 1-1. 2900-01 Block Diagram

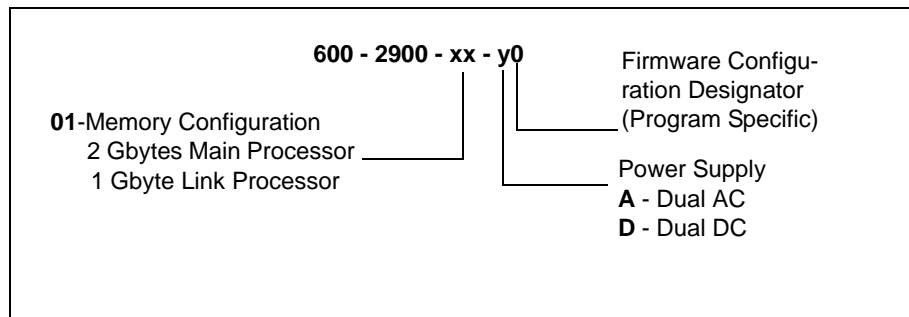
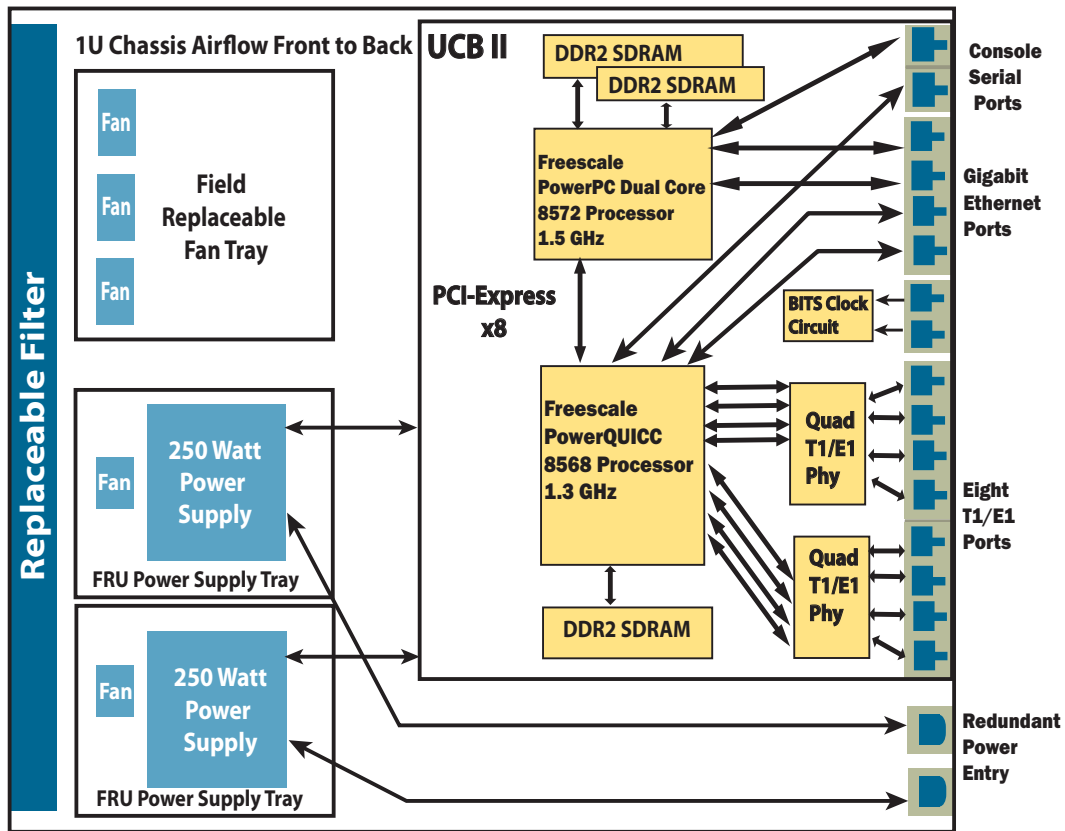

Figure 1-2. 2900 Part Numbering

1.2 SPECIFICATIONS

Table 1-1 lists the specifications for the 2900 Series Network Gateway. Cooling air input is on the front of the unit and the air exhaust is on the rear of the unit. Airflow should not be restricted; a minimum of one inch clearance on each side is required.

Table 1-1. 600-2900 Specifications

Physical	Height	1.72 inches
	Width	17 inches
	Depth	20 inches
	Other	19 inch rack mountable
	Weight	22 lbs
	Shipping Dimensions	25" wide x 23" deep x 10" high
Electrical - AC version	(600-2900-xx-A0)	
	Voltage:	90 - 264 Vac
	Current (typical)@115VAC:	1.2A
	Current(max)@115VAC	1.4A
	In Rush Current(max)@132VAC	<32A
	Power Dissipation:	494 BTU/hr.
	Frequency:	50-60 Hz
Electrical - DC version	(600-2900-xx-D0)	
	Voltage:	-36 to -72 Vdc
	Current(typical)@-48VDC	3.3A
	Current(max)-36-72VDC	4.8A - 2.4A
	In Rush Current (max) - 48VDC	<30A
	Power Dissipation:	494 BTU/hr.
Environmental	Operating Temperature	0 to 35 Degrees Celsius
	Relative Humidity	0% to 95% (non-condensing)
	Storage Temperature	-20 to 85 Degrees Celsius

1.3 REGULATORY COMPLIANCE

1.3.1 Safety

UL/CSA-609501, EN60950-1, IEC 609501 CB Scheme with all country deviations

1.3.2 RFI/EMC

Electromagnetic Emissions	
FCC CFR47 Part 15 Class A	<p><u>Note:</u> This equipment has been tested and found to comply with the limits for a Class A digital device, pursuant to Part 15 of the FCC Rules. These limits are designed to provide reasonable protection against harmful interference when the equipment is operated in a commercial environment. This equipment generates, uses and can radiate radio frequency energy and, if not installed and used in accordance with the instruction manual, may cause harmful interference to radio communications. Operation of this equipment in a residential area is likely to cause harmful interference in which case the user will be required to correct the interference at his own expense.</p>
CUL C22.2 No. 950	<p><u>Caution:</u> Changes or modifications to this equipment not expressly approved by the party responsible for compliance could void the user's authority to operate the equipment.</p> <p>This digital apparatus does not exceed the Class A limits for radio noise emissions from digital apparatus set out in the Radio Interference Regulations of the Canadian Department of Communication.</p> <p>The equipment or subassembly is suitable for connection to intrabuilding or non exposed wiring or cabling only.</p> <p>Le present apparall numerique n'emet pas de bruits radioelectriques depassant les limites applicables aux appareils numeriques de las classe A prescrites dans le Reglement sur le brouillage radioelectrique edicte par le ministere des Communications du Canada.</p>
CE Marking ICES-003	

Standard Number	Standard Name	Standard Date
EN55022	Information technology equipment - Radio disturbance characteristics - Limits and methods of measurement- Incorporates A1: 10/2007	2006
EN55024	Information technology equipment - Immunity characteristics - Limits and methods of measurement - Incorporates Amendment A2: 01/2003	1998
CNS13438	CNS13438, Class A: Limits and Methods of Measurement of Radio Disturbance Characteristics of Information Technology Equipment. CNS13438: Reference CISPR22 Class A.	2006

Standard Number	Standard Name	Standard Date
CISPR22	Information technology equipment- Radio disturbance characteristics - Limits and methods of measurement - Ratified European Text;	2006
EN61000-3-2	Electromagnetic compatibility (EMC) - Part 3-2: Limits - Limits for harmonic current emissions (equipment input current greater than or equal to 16 A per phase) - IEC 61000-3-2:2005	2006
EN61000-3-3	Electromagnetic Compatibility (EMC) - Part 3-3 Limits - Limitation of Voltage Changes, Voltage Fluctuations and Flicker in Public Low-Voltage Supply Systems, for Equipment with Rated Current ≤ 16 A per Phase and Not Subject to conditional connection.	2008

1.3.3 Immunity

EN55024/CISPR24

1.3.4 Telecommunications

NEBS Certification Requirements to NEBS Level-3 Criteria

GR-63-CORE Issue 3, March 2006

GR-1089-CORE Issue 3, October 2002

EN300-386 Harmonized European Telecom ERM and EMC Requirements (where a subset of NEBS)

EN300-019 Telecom Environmental (Where a subset of NEBS)

Anatel (Brazil) Certification

1.3.5 Other

Restriction of Hazardous Substances (RoHS) labeled, per WEEE (Waste Electrical and Electronics Equipment) directive (2002/95/EC)

1.3.6 Markings

CE, FCC, ICES-003, UL/cUL, RoHS, Anatel Brazil

2.1 PHYSICAL CONFIGURATION

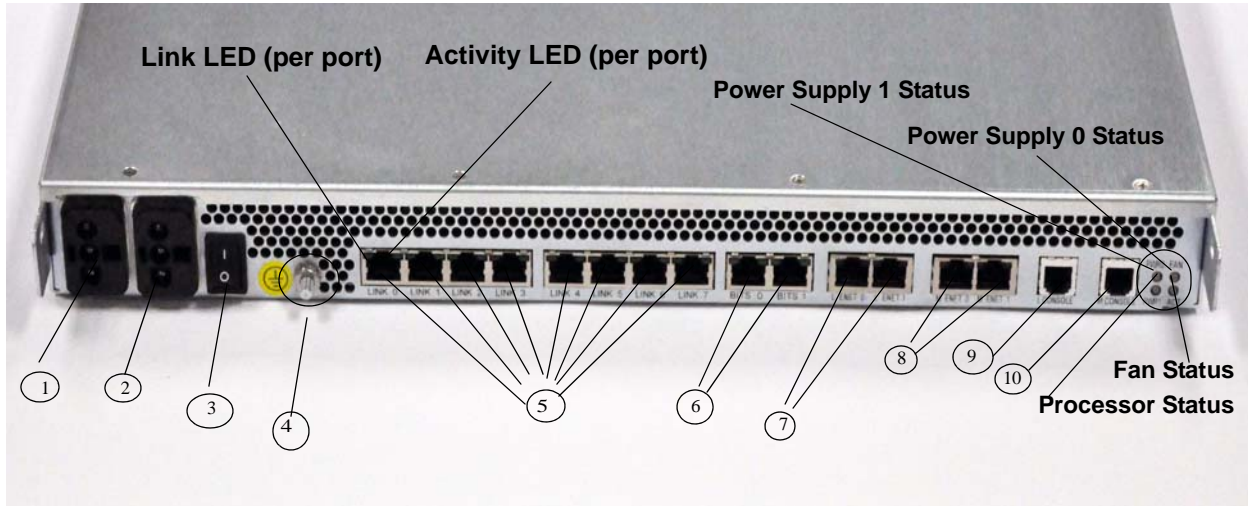

Figure 2-1. 600-2900 Rear Panel

Figure 2-1 shows a rear view of the 2900 unit. Table 2-1 identifies each item.

Table 2-1. 600-2900 Rear Panel Description

No.	Name
1	Power Connector A
2	Power Connector B
3	Power Supply ON/OFF Switch
4	Earthing Ground Stud Location
5	Link Ports 0-7
6	BITS Ports 0-1
7	Link Ethernet Ports 0-1
8	Main Ethernet Ports 0-1
9	Link Console Port
10	Main Console Port

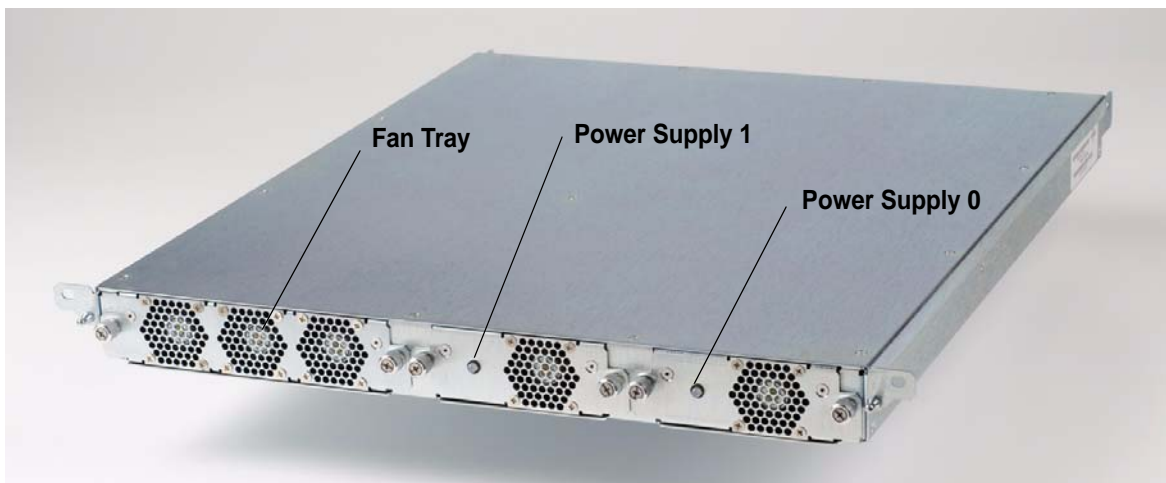
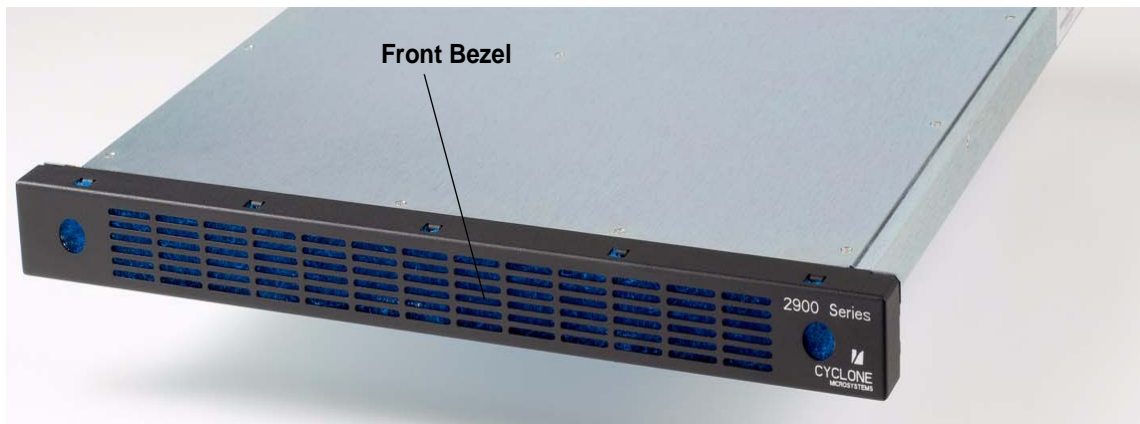

Figure 2-2. 600-2900 Front Panel with and without Front Bezel

2.1.1 2900 Power Supply Switch

The 600-2900-xx has a single power switch. This switch enables and disables both power supplies. The ‘1’ position indicates power supply ON and ‘0’ position indicates power supply OFF. The power switch does not disable the supply from the power mains. See Installation Guidelines in Chapter 3 and Safety Information in Appendix A.

2.2 CONNECTORS

2.2.1 Power Connector

There are two power supply connectors on the rear left hand side of the 2900.

2.2.1.1 DC Power Connectors (600-2900-xx-D0)

The DC power connector is a 3-pin connector. See Figure 2-6.

Mating Connector p/n-

Corcom GA310 Custom connector assembly with three, 36" long 18 gauge wires
or
Molex 03-12-1036 Connector housing
Molex 18-12-1222 Female Terminal (3 needed per housing)

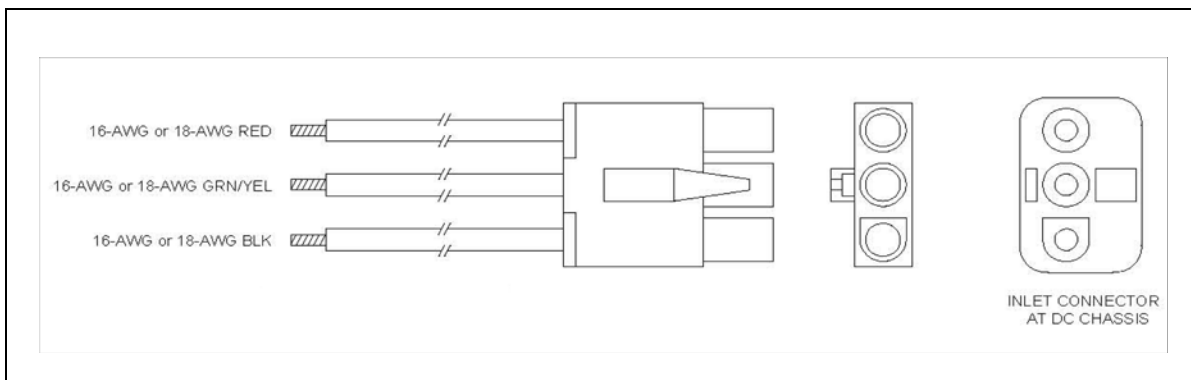

Figure 2-3. DC Power Connector

2.2.1.2 DC Power Supply Cable

Power cable should be composed of three, 36" long 18 gauge wires.

The color code for wire gauge for 600-2900-xx for DC power mating connector is as follows:

Red	-48VDC
Black	48VDC Return
Green & White	Ground

2.2.1.3 AC Power Connectors (600-2900-xx-A0)

The AC power connector is a 3-pin connector. See Figure 2-4

The Power Connector is a standard IEC type recessed power receptacle.

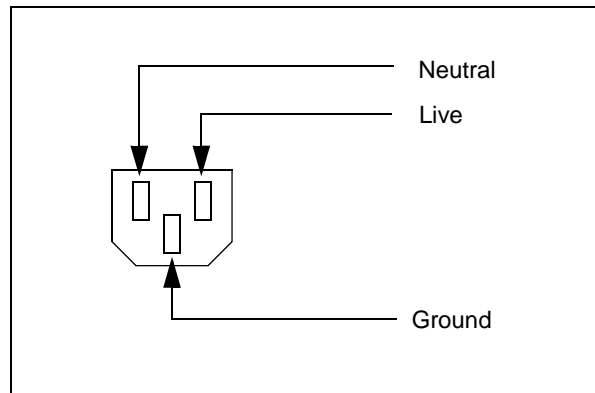

Figure 2-4. AC Power Connector

2.2.1.4 AC Power Supply Cable

- **Rating:** In the U.S. and Canada, cords must be UL (Underwriters Laboratories, Inc.) Listed/CSA (Canadian Standards Organization) Certified type SJT, 18-3 AWG (American Wire Gauge). Outside of the U.S. and Canada, cords must be flexible harmonized (<HAR>) or VDE (Verband Deutscher Elektrotechniker, German Institute of Electrical Engineers) certified cord with 3 x 0.75 mm conductors rated 250 VAC.
- **Connector, Wall Outlet end:** Cords must be terminated in grounding-type male plug designed for use in your region. The connector must have certification marks showing certification by an agency acceptable in your region and for U.S. must be Listed and rated 125% of overall current rating of the gateway.
- **Connector, gateway End:** The connectors that plug into the AC receptacle on the gateway must be an approved IEC (International Electrotechnical Commission) 320, sheet C13, type female connector.
- **Cord length and flexibility:** Cords must be less than 4.5 meters (14.8 feet) long.

2.2.2 Earthing Ground Stud

Earthing ground stud connection required for DC installations. There is a #10-32 threaded stud (with hex nuts, flat washers and star washers included) attached to the chassis. Ring lugs should be used to attached chassis ground to the ground studs. Table 2-4 shows AMP/Tyco part numbers for typical ring lugs for #10 studs.

Table 2-2. Ring Lugs for #10 Studs

Wire Gauge	AMP/Tyco Part
14-16 AWG	320630
10-12 AWG	36161

Figure 2-5. Earthing Ground Stud Location

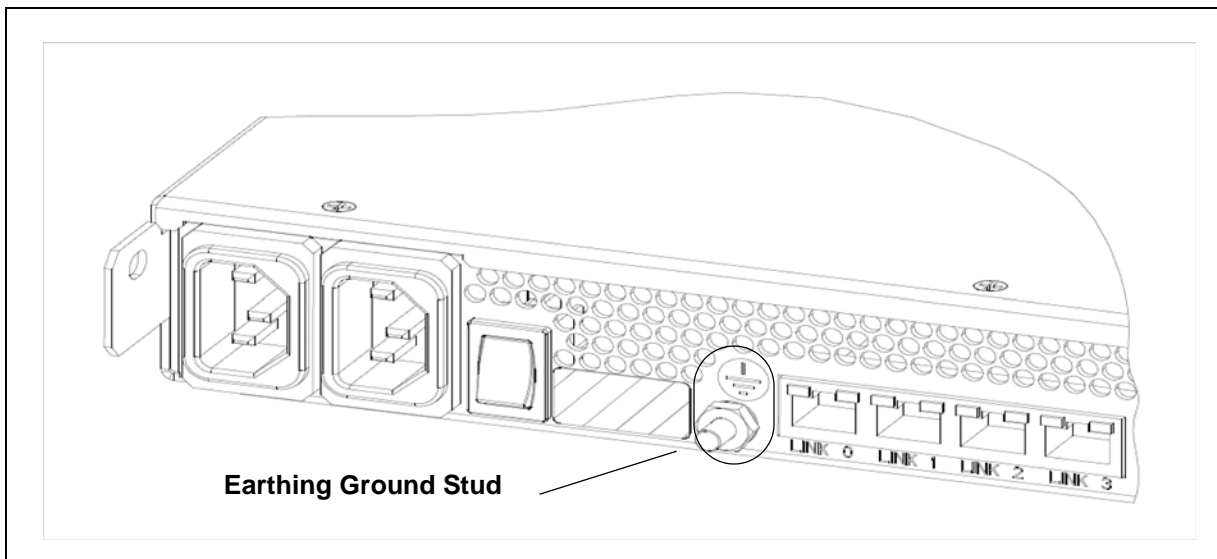

2.2.3 Console Connector

The Main and Link Console Connectors are narrow RJ11 (6 positions) phone jacks. The console port is an RS-232 serial port using a simple three-wire connection (transmit data, receive data, and ground). The connector assignment is as shown in Table 2-3. Normal system operation does not require a connection to the Main or Link console connector.

Diagnostic or debug activity may require connecting to the Main or Link console connectors. A cable connecting the console port to a standard DB9 connector is available from Cyclone Microsystems (P/N 530-2012-02). A terminal (or PC running a terminal emulation program) should be set up for any baud rate up to 115K baud, 8 bits, no parity and 1 stop bit.

Table 2-3. Console Port Connector

Pin	Signal	Description
1	-	N/C
2	TXD	Transmit Data
3	GND	Ground
4	-	N/C
5	RXD	Receive Data
6	-	N/C

2.2.4 Ethernet Port Connectors

The line interface of the Gigabit Ethernet ports is a shielded RJ4 (modular phone type) connector. The connector conforms to the 10/100/1000BaseT specification. The connectors exit the front panel of the 2900 in two pairs, one pair for the Main processor, the other pair for the Link processor. 10Base-T and 100Base-Tx mode, only two pairs are used, one for transmit and one for receive. In 1000Base-T mode, all four pairs are used.

2.2.4.1 Intra-Building Interfaces

All Ethernet ports are SELV only. All Ethernet ports are suitable for connection within a building only and are not intended for direct connection to TNV-1 (exposed plant leads/external digital network). All digital ports need to connect to the protected side of CSU/DSU.

Table 2-4. Ethernet Port Connector

Pin	Signal (10/100Base-T)	Description (10/100Base-T)	Signal (1000Base-T)	Description (1000Base-T)
1	TX+	Output	TP0+	Input/Output
2	TX-	Output	TP0-	Input/Output
3	RX+	Input	TP1+	Input/Output
4	-	Not Used	TP2+	Input/Output
5	-	Not Used	TP2-	Input/Output
6	RX-	Input	TP1-	Input/Output
7	-	Not Used	TP3+	Input/Output
8	-	Not Used	TP3-	Input/Output

2.2.5 Ethernet Port LEDs

Each Ethernet port has two green LEDs built into it's RJ45 connector. The "LINK" (link valid) LED indicates, when lit, that the port is attached to a functional ethernet network. The "ACT" (activity) LED indicates, when lit, that there is transmit or receive activity on the link. During normal operation, the "LINK" LED is on and the "ACT" LED blinks.

Figure 2-6. Ethernet Port LEDs

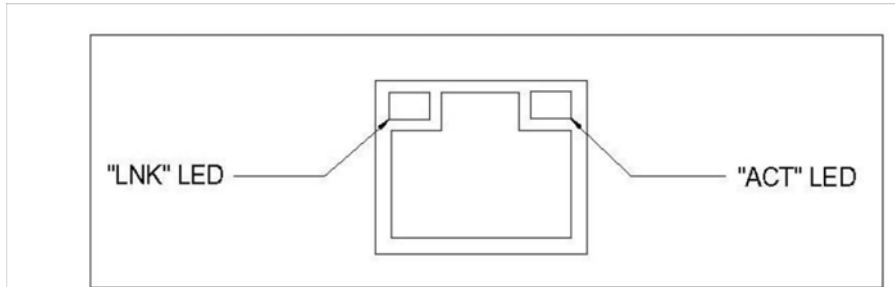

2.2.6 T1/E1 Connectors

The T1/E1 port connectors are an RJ45 connector. (8 position, 8 contact, shielded) modular type. The 2900 has over-voltage protection, over-current protection and line isolation on each transmit and receive line.

Table 2-5. T1/E1 Port Connector

Pin	Signal	Description
1	RX +	Receive "tip"
2	RX --	Receive "ring"
3	-	not used
4	TX +	Transmit "tip"
5	TX --	Transmit "ring"
6	-	Not Used
7	-	Not Used
8	-	Not Used

2.2.6.1 Intra-Building Interfaces

T1/E1 ports are SELV only. E1, T1/DS1 and similar digital ports are suitable for connection within a building only and are not intended for direct connection to TNV-1 (exposed plant leads/external digital network). All digital ports need to connect to the protected side of CSU/DSU.

2.2.7 T1/E1 Port LEDs

Each T1/E1 port has two green LEDs built into its RJ45 connector. The "LNK" (link valid) LED indicates, when lit, that the port is attached to a functional network. The "ACT" (activity) LED indicates, when lit, that there is transmit or receive activity on the link. During normal operation, the "LNK" LED is on and the "ACT" LED blinks.

Figure 2-7. T1/E1 Port LEDs

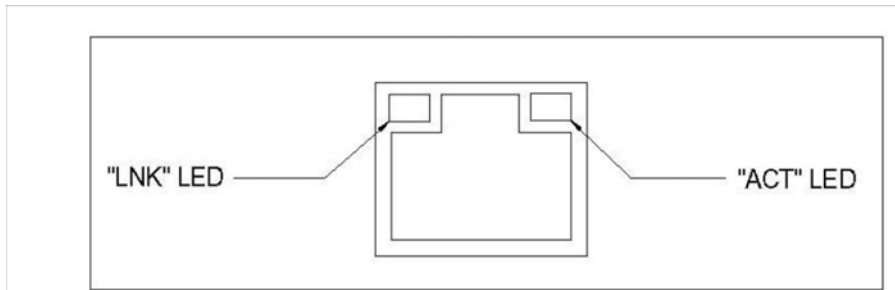

2.2.8 BITS Clock Connectors

The BITS clock connectors are an RJ45 (8 position, 8 contact, shielded) modular type. The 2900 has overvoltage protection, overcurrent protection and line isolation on each transmit and receive line.

Table 2-6. BITS Clock Connector

Pin	Signal	Description
1	RX +	Receive "tip"
2	RX --	Receive "ring"
3	-	not used
4	TX +	Transmit "tip"
5	TX --	Transmit "ring"
6	-	Not Used
7	-	Not Used
8	-	Not Used

2.2.9 BITS Clock LED

Each BITS clock port has two green LEDs built into it's RJ45 connector. The "LNK" (link valid) LED indicates, when lit, that the port is attached to a functional network. The other LED is not used. During normal operation with a valid BITS clock connected, the "LNK" LED is on. The BITS clock PHY directly controls the "LNK" LED.

Figure 2-8. BITS Clock Port LED

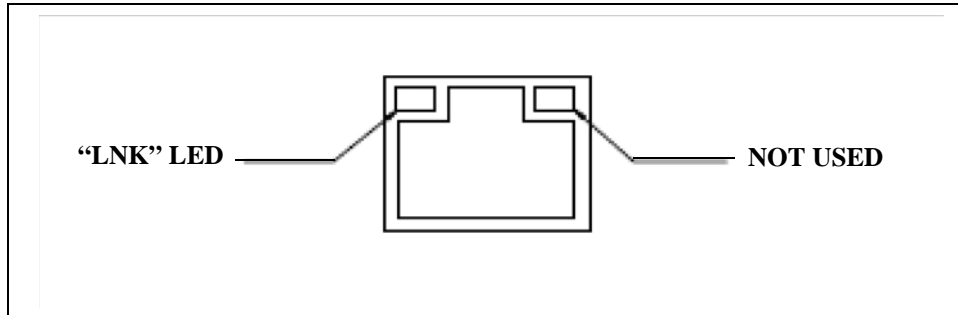

2.2.10 Processor ACT LED

Indicates the activity of the main processor.

Table 2-7. ACT LED

ACT LED	Status
OFF	Booting
RED	Box is in Reset
Blinking Green	U-Boot, VxWorks, and /or Application Booted.

2.2.11 Fan Status LED

Green on this LED indicates all the fans the Fan Tray are properly operating. Red on this LED indicates one or more of the fans are not properly operating or the tray is missing. The 2900 system will be properly cooled even with one failed fan.

2.2.12 Power Supply Status LEDs

Green on these LEDs indicates the respective supply is operating correctly. Red on these LEDs indicates the supply is not working or missing. The 2900 system will operate properly with one working supply.

Before You Begin

Before working with your gateway product, pay close attention to the safety instructions provided in this manual. See **Appendix A, “Safety Information”**.

3.1 CONSIDERATIONS

3.1.1 Equipment Rack Precautions

3.1.1.1 Anchor The Equipment Rack

The equipment rack must be anchored to an unmovable support to prevent it from falling over when one or more gateways are installed. The equipment rack must be installed according to the manufacturer's instructions. You must consider the weight of all devices installed in the rack.

3.1.2 Grounding the Equipment Rack

To avoid the potential for an electrical shock hazard, you must include a third wire safety ground conductor with the rack installation. If the gateway power cord is plugged into an outlet that is part of the rack, then you must provide proper grounding for the rack itself. If the gateway power cord is plugged into a wall outlet, the safety ground conductor in the power cord provides proper grounding only for the gateway. You must provide additional, proper grounding for the equipment rack and other devices installed in it.

3.1.3 Temperature

The operating temperature of the gateway, when installed in an equipment rack, must not go below 5°C (41°F) or rise above 35°C (95°F). Extreme fluctuations in temperature can cause a variety of problems in your gateway.

3.1.4 Ventilation

The equipment rack must provide sufficient airflow to the front of the gateway to maintain proper cooling. It must also include ventilation sufficient to exhaust a maximum of 494 BTU.

3.1.5 System References

All references to left, right, front, top, and bottom assume that you are facing the front of the gateway, as it would be positioned for normal operation.

3.1.6 Prerequisite Tools and Supplies

- No. 2 Phillips screwdriver.
- Ensure the availability of at least 1.75 inches of vertical space (slightly more vertical space than the mounting bracket) to accommodate the 2900 Series gateway.

3.2 INSTALLATION INSTRUCTIONS

3.2.1 Install Rack Mounted Rails

The rack-mounting kit allows you to mount your 2900 Series gateway into a standard 19-inch equipment rack.

Unpack the two rails supplied with the gateway. The rails ship from Cyclone Microsystems adjusted for a 22 inch depth cabinet. If your rack is different depth, loosen the two inside screws to adjust the rail to the needed depth. Retighten the screws. Left rail and right rails are discerned by observing the raised vertical tabs with threaded hole. The raised vertical tabs mount to the back of the gateway.

Mount the rails to the vertical rack posts using two #10-32, 1/2 inch Phillips Pan Head Screw and two mating G-Style Clip on nut on both the front and back of each rail section.

3.2.2 Install the Gateway into a Rack

Gently slide the gateway onto the rails and fasten the rear gateway retaining screw on both rails.

On the front of the gateway use two #10-32, 1/2 inch Phillips Pan Head Screw and two mating G-Style Clip on nuts to secure both the left and right rack mount ear tabs of the gateway to the front vertical rack posts.

3.2.3 Connect Gateway to Earthing Ground

To avoid the potential for an electrical shock hazard, you must reliably connect an earthing ground conductor to the gateway. The earthing ground conductor on the DC power configuration is a #10 earthing ground stud on the front panel. The earthing ground stud provides proper grounding only for the gateway. You must provide additional proper grounding for the rack and other devices installed in it. See Section 2.2.2 Earthing Ground Stud for information on the ring lugs and wire gauge.

3.2.4 Connecting DC Power

Connection with a DC (Direct Current) source should only be performed by trained service personnel. The gateway with DC input is to be installed in a Restricted Access Location in accordance with articles 110-26 and 110-27 of the National Electric Code, ANSI/NFPA 70. The DC source must be electrically isolated by double or reinforced insulation from any hazardous AC source. The DC source must be capable of providing up to 250 watts of continuous power per feed pair.

Mains DC power disconnect: You are responsible for installing a properly rated DC power disconnect for the gateway system. This mains disconnect must be readily accessible, and it must be labeled as controlling power to the gateway. The UL Listed circuit breaker of a centralized DC power system may be used as a disconnect device when easily accessible and should be rated no more than 5 amps. To remove all power to the gateway, first turn the unit off and then disconnect both power supply cables.

Grounding the gateway: This gateway is intended for installation with an isolated DC return (DC-I) and is to be installed in a Common Bonding Network (CBN) per NEBS GR-1089.

3.2.5 Connecting AC Power

The plugs on the power supply cables are considered the mains disconnect for the gateway and must be readily accessible when installed. If the individual gateway power supply cable plugs will not be readily accessible for disconnection then you are responsible for installing a power disconnect for the entire rack unit. This main disconnect must be readily accessible, and it must be labeled as controlling power to the entire rack, not just to the gateway(s). To remove all power to the 2900, first turn unit off and then remove both power supply cable plugs.

3.3 INSTALLATION GUIDELINES

The following guidelines and instructions apply to the 600-2900-xx-DC and the 600-2900-xx-AC.

1. This unit is for use only in a Restricted Access Location (RAL).
2. Do not connect or disconnect the power supply connector (Section 2.2.1) under load.
3. The DC power supply cord must be protected against physical damage.
4. Elevated Operating Ambient - If installed in a closed or multi-unit rack assembly, the operating ambient temperature of the rack environment may be greater than room ambient. Therefore, consideration should be given to installing the equipment in an environment compatible with the maximum ambient temperature (T_{ma}) specified by the manufacturer.
5. Reduced Air Flow - Installation of the equipment in a rack should be such that the amount of air flow required for safe operation of the equipment is not compromised.
6. Mechanical Loading - Mounting of the equipment in the rack should be such that a hazardous condition is not achieved due to uneven mechanical loading.
8. Circuit Overloading - Consideration should be given to the connection of the equipment to the supply circuit and the effect that overloading of the circuits might have on overcurrent protection and supply wiring. Appropriate consideration of equipment nameplate ratings should be used when addressing this concern.
9. Reliable Earthing - Reliable earthing of rack-mounted equipment should be maintained. Particular attention should be given to supply connections other than direct connections to the branch circuit (e.g. use of power strips).

10. Ethernet Cabling Warning: The intra-building port(s) of the equipment or subassembly is suitable for connection to intrabuilding or unexposed wiring or cabling only. The intra-building port(s) of the equipment or subassembly **MUST NOT** be metalically connected to interfaces that connect to the OSP or its wiring. These interfaces are designed for use as intra-building interfaces only (Type 2 or Type 4 ports as described in GR-1089-CORE, Issue 4) and require isolation from the exposed OSP cabling. The addition of primary Protectors is not sufficient protection in order to connect these interfaces metalically to OSP wiring.

4.1 PERIODIC MAINTENANCE

The only element of the 2900 unit requiring periodic maintenance is the air filter, located on the front of the unit. The filter should be replaced or cleaned every 12 months in normal operating environments. It should be replaced or cleaned more often in dusty environments. The filter may be washed with water.

The replacement of air filter or fan can be done without turning off the power supplies. The air filter assembly is located on the front of the FEP unit. Replacement filters can be purchased from Cyclone Microsystems, Cyclone part number 370-R1508.

Table 4-1. Air Filter Replacement

1	Remove Front Bezel by Pulling on Finger Holes
2	Remove Air Filter by Pinching Filter Material
3	Wash Filter in Water
4	Install Clean or New Filter in Bezel by Pinching Filter Material and Inserting under Retaining Tabs
5	Reinstall Bezel on System by Pressing Bezel onto Mounting Studs

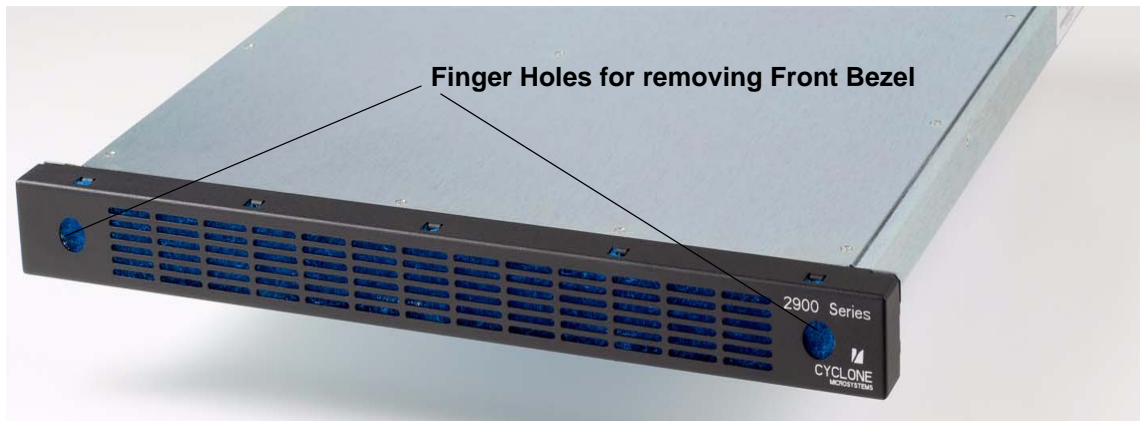
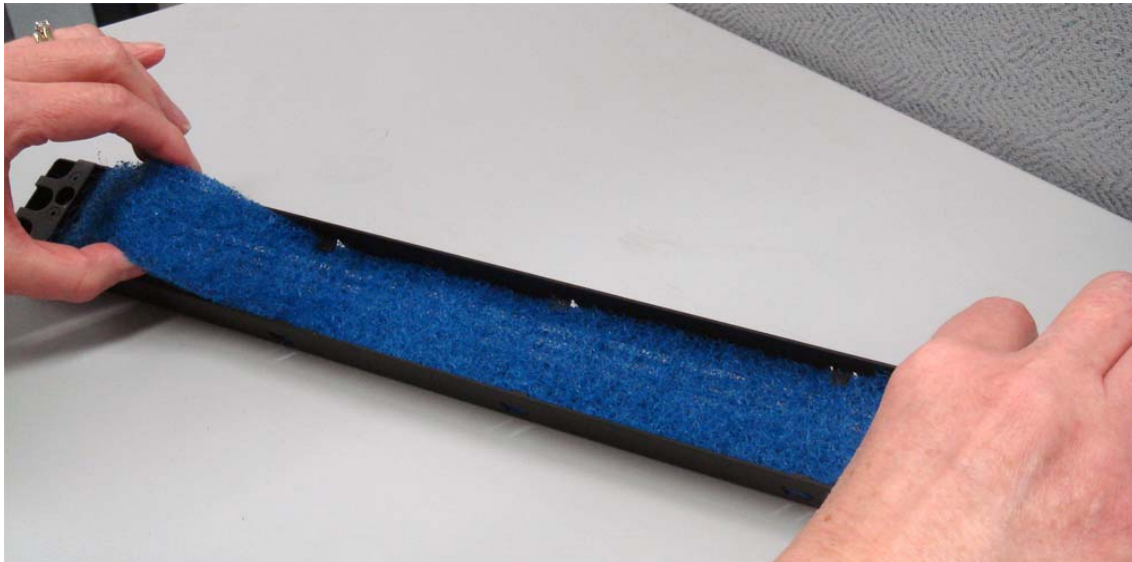

Figure 4-1. Air Filter Replacement

Figure 4-2. Pinching Filter Material



CHAPTER 5 SERVICEABLE COMPONENTS

5.1 SERVICEABLE COMPONENTS

All of the Field Replaceable Units (FRU) of an FEP are serviceable from the front of the unit without the need to dismount an installed FEP from its rack. Table 6-1 lists all the field replaceable units and the associated CLEI codes and Cyclone part numbers.

Table 5-1. CLEI Number and Barcode

Cyclone Part Number	Qty	Description	CLEI Number	ECI Code Barcode
600-2900-xx-A0				
600-2020A	1	2900AC Chassis	ANM3J00ERA	460021
550-0833	1	MB-833 Processor Mother Board	ANC5AAFDA	172338
370-R1500	2	AC Power Supply: 2900 Chassis	ANPUE60MAA	172482
370-R1502	1	Fan Tray: 2900 Chassis	ANC5AAGDA	172344
370-R1506	1	Bezel Filter Assembly: 2900 Chassis		
370-R1508	1	Filter (only): 2900 Chassis	ANPQABVPAA	172345
600-2900-xx-D0				
	1	2900DC Chassis	ANM3K00ERA	460022
550-0833	1	MB-833 Processor Mother Board	ANC5AAFDA	172338
370-R1501	2	DC Power Supply: 2900 Chassis	ANPUF60MAA	172343
370-R1502	1	Fan Tray: 2900 Chassis	ANC5AAGDA	172344
370-R1506	1	Bezel Filter assembly: 2900 Chassis		
370-R1508	1	Filter (only): 2900 Chassis	ANPQABVPAA	172345

5.2 MOTHERBOARD REMOVAL AND INSTALLATION

Caution: Both power supply input cables must be removed before servicing any internal components.

The MB-833 Processor Mother Board can be field replaced or replaced at the factory. In order to replace the motherboard both power supply input cables must be disconnected by removing the plug from the socket. The chassis must be removed from the rack. The circuits on the MB-833 are static sensitive. Specifically, boards should only be actively handled with a ground strap and transported in an ESD shielded bag. Please refer to Table 6-2 for motherboard removal procedure and Table 6-3 for motherboard installation procedure.

Table 5-2. Motherboard Removal

1	Remove Input Power Supply Plugs
2	Remove Earthing Ground
3	Remove Chassis from Rack
4	Wear Ground Strap and take Anti-Static Precautions
5	Remove Top of Chassis by Removing 13 Screws and Lifting Top off
6	Remove Front Bezel
7	Loosen Thumb Screws on Fan Tray and Slide Fan Tray out
8	Remove Internal Power Connector from Board
9	Remove Six Motherboard Mounting Screws
10	Slide Motherboard towards front of chassis until RJ45 connectors clear Rear Panel
11	Lift out Motherboard
12	Properly Store Motherboard in an Antistatic Bag

Table 5-3. Motherboard Installation

1	Assuming directions from Table 6-2 - Motherboard Removal was followed and Chassis is open, Check that Fan Tray is Removed. If not, do so.
2	Place Replacement Motherboard on Standoffs Inside of Chassis
3	Install two front corner Mounting Screws in Oval Holes, but do not tighten
4	With palms of hand on rear edge of chassis, press with fingers on back of the RJ45 connector housings until connectors seat in rear panel. Tighten mounting screws
5	Install Remaining Four Mounting Screws
6	Connect Internal Power Connector to Motherboard
7	Insert Fan Tray and Tighten Thumb Screws
8	Install Chassis Top and 13 Screws
9	Reinstall in Rack
10	Reinstall Earthing Ground
11	Plug in Two Power Supply Cables

5.3 FAN TRAY REMOVAL AND INSTALLATION

The cooling fans of the 2900 are serviceable from the front of the unit. The FEP does NOT have to be removed from its rack to service the fans. The Fan tray maybe removed and installed while the system is running.

Table 5-4. Fan Tray Removal and Installation

Removal	
1	Remove Front Bezel by Pulling on Finger Holes (se Figure 5-1)
2	Remove Fan Tray by loosening thumb screws and pulling tray out of chassis
Installation	
1	Insert Fan Tray and hand tighten thumb screws
2	Reinstall Front Bezel by pressing it into place

5.4 POWER SUPPLY REMOVAL AND INSTALLATION

The power supplies of the 2900 are serviceable from the front of the unit. The 2900 does NOT have to be removed from its rack to service the power supplies. The 2900 will operate with one power supply installed. Since the power supplies are designed to hot swap, they can be removed or installed without switching off the power.

Figure 5-1. Air Filter Replacement

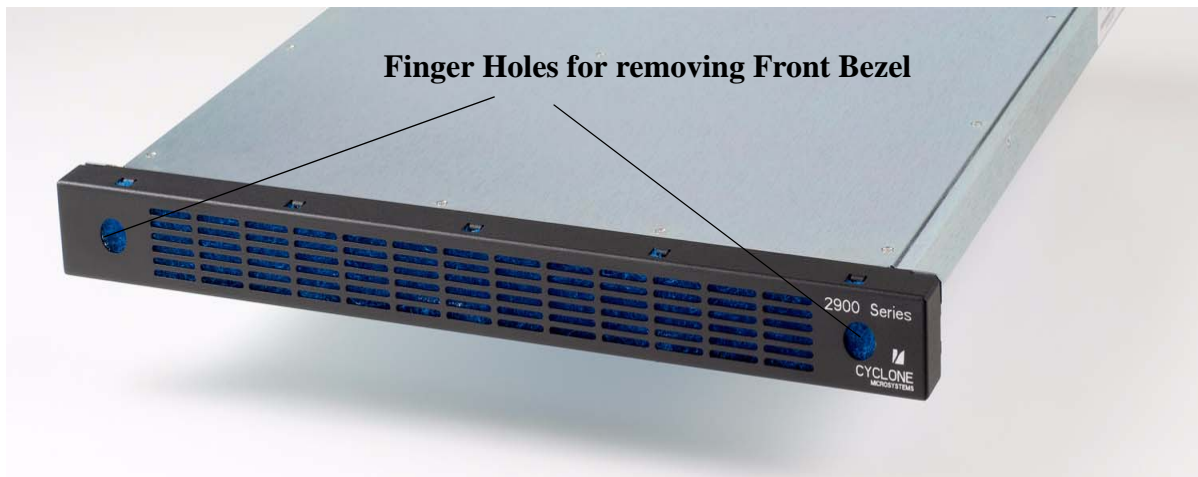
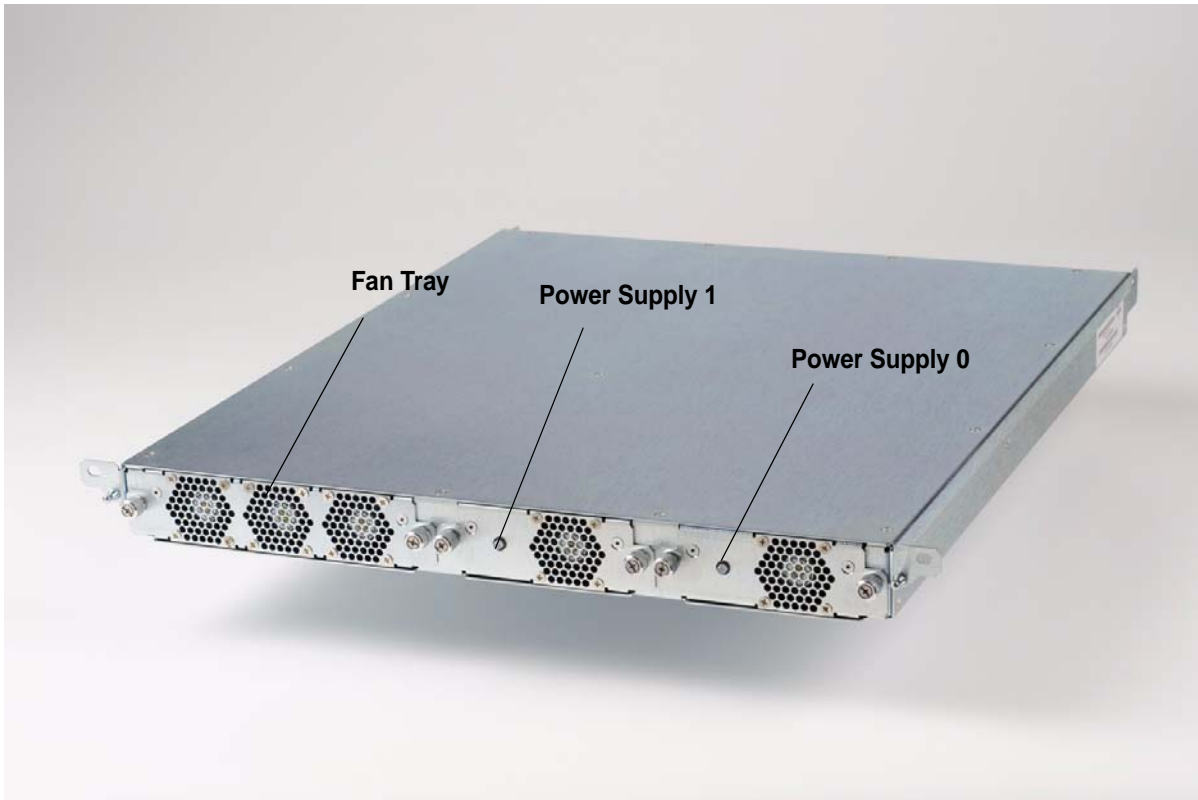

Figure 5-2. 600-2900 Front Panel



5.4.1 Power Supply Removal

Remove the front bezel, loosen the two retaining thumb screws, at either end of the power supply. Eject the power supply from the 2900 by pulling outward on the thumb screws. Pull the power supply from the unit.

5.4.2 Power Supply Installation

Remove the front bezel, slide the power supply into the 2900. Fully seat the power supply and tighten the retaining thumb screws. Replace the front bezel.

6.1 METHODOLOGY

Reliability predictions were completed using the Bellcore 5 reliability standard developed by AT&T Bell Laboratories. Component failure rates are calculated based on technology, stress levels, gate or transistor density (ICs), package style, and quality level. Failure rates provided by the component manufacturer have been used in some cases, where available. Failure rates are expressed in FITs, which is failures per billion hours. Mean Time Between Failures (MTBF) is the inverse of the failure rate and is the average time between failures.

6.2 ASSUMPTIONS

- Ambient input air temperature does not exceed 30 deg. C.
- Ground, Fixed, Controlled Environment
- Components are Quality Level I.
- Component stress levels do not exceed rated limits (i.e. power dissipation, junction temperature, etc.). In other words, components are used within specification limits. The parts count prediction assumes parts are used at a maximum of 50% of rated electrical stress.
- Component failure could result in FEP failure (except for the power supplies that are configured in parallel redundancy). However, Telcordia's architecture uses FEPs in parallel redundancy.

6.3 CONFIGURATION

Item	Part Number	Failure Rate 30° C	MTBF 30° C
	600-2900-01-D0		
MB-833	550-0833	2150	465,116
DC Power Supply	370-R1501	3781	264,480
Fan Assembly	370-R1502	28,571	35,000
	MTBF		
	600-2900-01-A0		
MB-833	550-0833	2150	465,116
AC Power Supply	370-R1500	3781	264,480
Fan Assembly	370-R1502	28,571	35,000

7.1 OVERVIEW

Cyclone Microsystems is a commercial manufacturer of Single Board Computers, Intelligent Communication Controllers and Communications Systems. Our standard repair cycle for in-warranty or out-of-warranty repair is two weeks. Most of our FEP customers require 24 by 7 support that is far in excess of Cyclone Microsystems' current or anticipated capabilities. Consequently, we highly recommend that FEP customers pursue high availability support from a support organization or pursue an on-site sparing policy in conjunction with a Cyclone Microsystems Expedited Repair Program. Please contact a Cyclone sales representative for a program proposal.

7.2 HARDWARE

Cyclone Microsystems, Inc. (Cyclone) for the period set out below, warrants that its standard products will be free from defects in workmanship or material under normal use and service. Cyclone's obligation under this warranty shall not arise until the Buyer returns the defective product, freight prepaid, to Cyclone. The only responsibilities of Cyclone under this warranty are at its option to replace or repair, without charge, any defective component of such products.

7.3 SOFTWARE AND FIRMWARE

Cyclone warrants that Software and Firmware supplied shall conform to the then current published documentation applicable to such programs. Cyclone, for the effective period of the warranty set out below, will upon written notice from the Buyer documenting the symptoms or the defect, expend its best efforts to resolve software bugs and/or fault. This service shall be without extra charge, and at Cyclone's option may include on-site visit(s) if in its opinion the conditions justify such visit(s).

7.4 EFFECTIVE PERIOD OF WARRANTY

One year from date of delivery.

7.5 REPAIRED OR REPLACEMENT PRODUCT (OUT-OF-WARRANTY)

Cyclone Microsystems, for a period of 30 days, warrants that its out-of-warranty products that are repaired or replaced shall be free from defects in workmanship or material under normal use and service.

Any repair or replacement shall not extend the period within which the warranty can be asserted.

The above warranties do not extend to and shall not apply to:

- Products which have been repaired or altered by other than Cyclone, unless the Buyer has properly altered or repaired the products in accordance with procedures previously approved, in writing, by Cyclone; or
- Products which have been subject to misuse, neglect, accident or improper installation; or

WARRANTY



- Products not manufactured by Cyclone.

The foregoing warranty and remedies are exclusive and are made in lieu of all other warranties express or implied, either in fact or by operation of law, statutory or otherwise, including warranties of merchantability and fitness for use. Cyclone neither assumes nor authorizes any other person to assume for it any other liability in connection with the sale, installation or use of its products, and Cyclone makes no warranty whatsoever for products not manufactured by Cyclone or with respect to any non-standard products which have been subject to misuse, neglect, accident, or have been modified by the Buyer. Cyclone shall have no liability for incidental or consequential damages of any kind arising out of the sale, installation, or use of its products.

7.6 SERVICE POLICY

Out-of-Warranty repair will be accomplished expeditiously at a charge published on the current price schedule plus shipping. A full description of the failure must be enclosed with the product.

Shipments arriving at Cyclone without a Return Material Authorization (RMA) number will not be accepted and will be returned to the customer at his cost regardless of warranty status.

Return Procedures

Upon determining that repair is required, the customer must:

- Call Cyclone Customer Support at (203) 786-5536 for a RMA number. Please have ready:
 - The serial number of the board (s)
 - The reason for return
- Enclose a detailed description of the failure with the failed unit in a static-shielded protective container.
- Ship unit to: Cyclone Microsystems, 2 Mountain View Drive, Shelton, CT 06484, Attn: RMA number
- The RMA is valid for 30 days after issue.

APPENDIX A SAFETY INFORMATION

Warning: Although you may be using this guide or another resource as a reference, before working with your gateway product pay close attention to these safety instructions. You must adhere to the assembly instructions in this guide to ensure and maintain compliance with existing product certifications and approvals. Use only the described, regulated components specified in this guide. Use of other products / components will void the UL listing and other regulatory approvals of the product and will most likely result in noncompliance with product regulations in the region(s) in which the product is sold.

A.1 INTENDED USES

This product was evaluated as Information Technology Equipment (ITE), which may be installed in Central Offices, Telecommunication Centers, Network Telecommunication Facilities, computer rooms, and similar commercial type locations where The National Electric Code (NEC) applies. The suitability of this product for other product categories and environments other than an ITE application, may require further evaluation.

DC Input Version:

The gateway with DC input is to be installed in a Restricted Access Location in accordance with articles 110-26 and 110-27 of the National Electric Code, ANSI/NFPA 70.

To avoid the potential for an electrical shock hazard, you must connect the DC gateway to an earthed mains socket-outlet.

A.2 EQUIPMENT RACK

Anchor the equipment rack: The equipment rack must be anchored to an unmovable support to prevent it from falling over when one or more gateways are extended in front of the rack on slides. You must also consider the weight of any other device installed in the rack. A crush hazard exists should the rack tilt forward which could cause serious injury.

A.3 POWER

The power button on the system does not turn off system power. To remove power from the system, you must unplug each power supply cable from the wall outlet or power supply.

The power supply cable is considered the disconnect device to the main (AC) power. The socket outlet that the system plugs into must be installed near the equipment and must be easily accessible.

A.4 IF AC POWER SUPPLIES ARE INSTALLED

The plug on the power supply cable are considered the mains disconnect for the gateway and must be readily accessible when installed. If the individual gateway power supply cable plugs will not be readily accessible for disconnection then you are responsible for installing a power disconnect for the entire rack unit. This main disconnect must be readily accessible, and it must be labeled as controlling power to the entire rack, not just to the gateway(s). To remove all power to the 2900, first turn the unit off and then remove both power supply cable plugs.

Grounding the rack installation: To avoid the potential for an electrical shock hazard, you must include a third wire safety ground conductor with the rack installation. If the gateway power cord is plugged into an AC outlet that is part of the rack, then you must provide proper grounding for the rack itself. If the gateway power cord is plugged into a wall AC outlet, the safety ground conductor in the power cord provides proper grounding only for the gateway. You must provide additional, proper grounding for the rack and other devices installed in it. This system is intended for connection to a Common Bonding Network (CBN) as defined by NEBS GR-1089.

Warning: Do not attempt to modify or use an AC power cord set that is not the exact type required. You must use a power cord set that meets the following criteria:

- **Rating:** In the U.S. and Canada, cords must be UL (Underwriters Laboratories, Inc.) Listed/CSA (Canadian Standards Organization) Certified type SJT, 18-3 AWG (American Wire Gauge). Outside of the U.S. and Canada, cords must be flexible harmonized (<HAR>) or VDE (Verband Deutscher Elektrotechniker, German Institute of Electrical Engineers) certified cord with 3 x 0.75 mm conductors rated 250 VAC.
- **Connector, Wall Outlet end:** Cords must be terminated in grounding-type male plug designed for use in your region. The connector must have certification marks showing certification by an agency acceptable in your region and for U.S. must be Listed and rated 125% of overall current rating of the gateway.
- **Connector, gateway End:** The connectors that plug into the AC receptacle on the gateway must be an approved IEC (International Electrotechnical Commission) 320, sheet C13, type female connector.
- **Cord length and flexibility:** Cords must be less than 4.5 meters (14.8 feet) long.

A.5 IF DC POWER SUPPLIES ARE INSTALLED

Connection with a DC (Direct Current) source should only be performed by trained service personnel. The gateway with DC input is to be installed in a Restricted Access Location in accordance with articles 110-26 and 110-27 of the National Electric Code, ANSI/NFPA 70. The DC source must be electrically isolated by double or reinforced insulation from any hazardous AC source. The DC source must be capable of providing up to 250 watts of continuous power per feed pair.

Mains DC power disconnect: You are responsible for installing a properly rated DC power disconnect for the gateway system. This mains disconnect must be readily accessible, and it must be labeled as controlling power to the gateway. The UL Listed circuit breaker of a centralized DC power system may be used as a disconnect device when easily accessible and should be rated no more than 5 amps. To remove all power to the gateway, first turn the unit off and then disconnect both power supply cables.

Grounding the gateway: This gateway is intended for installation with an isolated DC return (DC-I) and is to be installed in a Common Bonding Network (CBN) per NEBS GR-1089.

To avoid the potential for an electrical shock hazard, you must reliably connect an earth grounding conductor to the gateway. The earth grounding conductor on the DC power configuration is a #10 earthing ground stud on the front panel. The earthing ground stud provides proper grounding only for the gateway. You must provide additional, proper grounding for the rack and other devices installed in it. See section 2.2.2 Earthing Ground Stud for information on ring lugs and wire gauge.

A.6 TEMPERATURE

The temperature, in which the gateway operates when installed in an equipment rack, must not go below 5°C (41°F) or rise above 35°C (95°F). Extreme fluctuations in temperature can cause a variety of problems in your gateway.

A.7 VENTILATION

The equipment rack must provide sufficient airflow to the front of the gateway to maintain proper cooling. The rack must also include ventilation sufficient to exhaust a maximum of 494 BTUs (British Thermal Units) per hour for the gateway. The rack selected and the ventilation provided must be suitable to the environment in which the gateway will be used.